

OPERATING INSTRUCTIONS AND SPECIFICATIONS

# NI 9237

## 4-Channel, 24-Bit Half/Full-Bridge Analog Input Module

Français Deutsch 日本語 한국어 简体中文

[ni.com/manuals](http://ni.com/manuals)

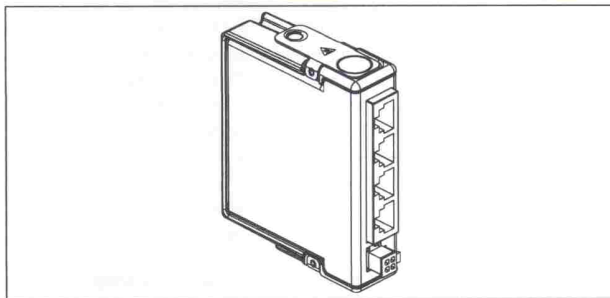

This document describes how to use the National Instruments 9237 and includes specifications and pin assignments for the NI 9237. Visit [ni.com/info](http://ni.com/info) and enter `rdsoftwareversion` to determine which software you need for the modules you are using. For information about installing, configuring, and programming the system, refer to the system documentation. Visit [ni.com/info](http://ni.com/info) and enter `cseriesdoc` for information about C Series documentation.



**Note** The safety guidelines and specifications in this document are specific to the NI 9237. The other components in the system might not meet the same safety ratings and specifications. Refer to the documentation for each component in the system to determine the safety ratings and specifications for the entire system. Visit [ni.com/info](http://ni.com/info) and enter `cseriesdoc` for information about C Series documentation.

## Safety Guidelines

Operate the NI 9237 only as described in these operating instructions.



**Hot Surface** This icon denotes that the component may be hot. Touching this component may result in bodily injury.

## Safety Guidelines for Hazardous Locations

The NI 9237 is suitable for use in Class I, Division 2, Groups A, B, C, D, T4 hazardous locations; Class I, Zone 2, AEx nC IIC T4, and Ex nC IIC T4 hazardous locations; and nonhazardous locations only. Follow these guidelines if you are installing the NI 9237 in a potentially explosive environment. Not following these guidelines may result in serious injury or death.



**Caution** Do *not* disconnect I/O-side wires or connectors unless power has been switched off or the area is known to be nonhazardous.



**Caution** Do *not* remove modules unless power has been switched off or the area is known to be nonhazardous.



**Caution** Substitution of components may impair suitability for Class I, Division 2.



**Caution** For Zone 2 applications, install the system in an enclosure rated to at least IP 54 as defined by IEC 60529 and EN 60529.



**Caution** For Zone 2 applications, connected signals must be within the following limits:

Capacitance ..... 0.2  $\mu$ F max

Inductance ..... 80 mH max

### Special Conditions for Hazardous Locations Use in Europe

This equipment has been evaluated as EEx nC IIC T4 equipment under DEMKO Certificate No. 03 ATEX 0324020X. Each module is marked  II 3G and is suitable for use in Zone 2 hazardous locations. If you are using the NI 9237 in Gas Group IIC hazardous locations or in ambient temperatures of  $-40\text{ }^{\circ}\text{C} \leq T_a \leq 70\text{ }^{\circ}\text{C}$ , you must use the device in an NI chassis that has been evaluated as EEx nC IIC T4, Ex nA IIC T4, or Ex nL IIC T4 equipment.

### Special Conditions for Marine Applications

Some modules are Lloyd's Register (LR) Type Approved for marine applications. To verify Lloyd's Register certification, visit [ni.com/certification](http://ni.com/certification) and search for the LR certificate, or look for the Lloyd's Register mark on the module.



**Caution** To meet radio frequency emission requirements for marine applications, use shielded cables and install the system in a metal enclosure. Suppression ferrites must be installed on power supply inputs near power entries to modules and controllers. Power supply and module cables must be separated on opposite sides of the enclosure and must enter and exit through opposing enclosure walls.

## Connecting the NI 9237

The NI 9237 has four RJ-50 receptacles that provide connections for four half or full bridges.

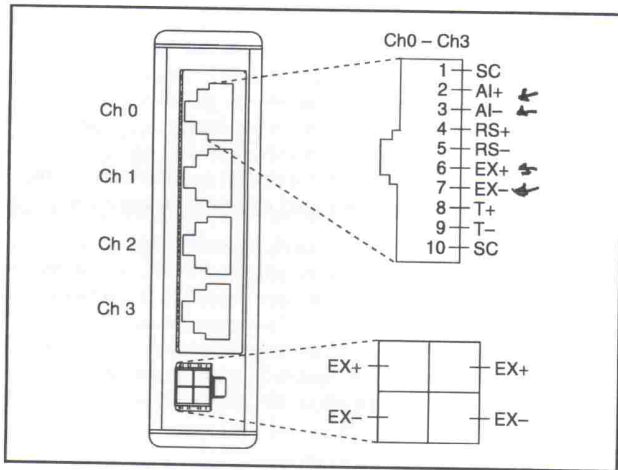

Figure 1. NI 9237 Pin Assignments

When you connect a half bridge to the NI 9237, you must connect the AI+, EX-, and RS- signals, but you do not connect the AI- signal. When you connect a full bridge, you must connect the AI+, AI-, EX-, and RS- signals. Refer to Figure 2 for an illustration of how to connect half and full bridges to the NI 9237.



**Note** You can use a quarter bridge with the NI 9237 if you add a resistor externally to create a half bridge. You also can use a quarter bridge with the NI 9237 if you use the NI 9944 or NI 9945 Quarter Bridge Completion Accessory. Visit [ni.com](http://ni.com) and search for the NI 9944 and NI 9945 Quarter Bridge Completion Accessories for more information about these accessories and how to purchase them.



**Note** National Instruments does not recommend using an RJ-45 cable with the NI 9237 because it can physically damage pins 1 and 10 on the device, and thus permanently disable shunt calibration no matter what connector you use.

The NI 9237 has a four-terminal external excitation voltage source connector. You can use the EX+ and EX- terminals on the connector to connect one external excitation voltage source to the module. You can use the additional EX+ and EX- terminals on the connector to wire multiple NI 9237 modules together in a daisy chain.



**Note** When you insert or remove a new sensor from the NI 9237, slight changes in the excitation voltages can cause a mismatch between the internal half-bridge completion resistors and the half-bridge sensors, which results in a change in the measurement offsets. National Instruments recommends performing bridge calibrations of quarter- or half-bridge sensors after connecting all sensors to the NI 9237 and after removing or attaching any additional sensor. Visit [ni.com/info](http://ni.com/info) and enter the info code `rdw9237` for more information about changes in voltage offsets in the NI 9237.

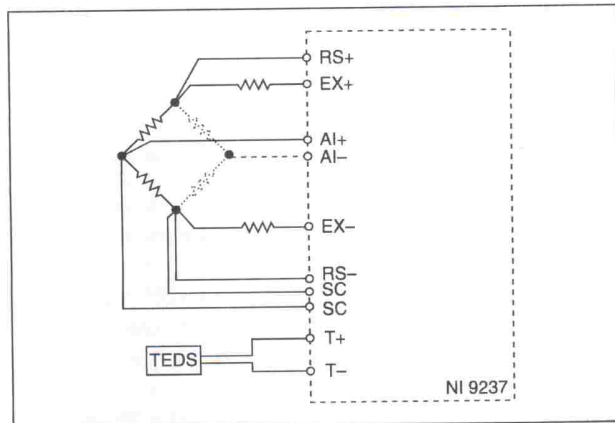

**Figure 2.** Connecting a Half or Full Bridge to the NI 9237

Each channel on the NI 9237 has an independent 24-bit ADC and an input amplifier that enable you to sample signals from all four channels simultaneously.

The NI 9237 is isolated from earth ground. However, the individual channels are not isolated from each other. The EX+, EX-, and T- signals are common among all channels. You can connect the NI 9237 to a device that is biased at any voltage within the NI 9237 rejection range of earth ground. Refer to the *Specifications* section for more information about the common-mode rejection ratio (CMRR).

You also can connect floating signals to the NI 9237. If you connect floating signals to the NI 9237, National Instruments recommends connecting the EX- signal to the earth ground or shield for better noise rejection.

The NI 9237 also includes filters to prevent aliasing. The filters on the NI 9237 filter according to the data rate. Refer to the *Understanding NI 9237 Filtering* section for more information about filtering.

## Wiring TEDS Channels

Ensure that neither the TEDS data (T+) nor the TEDS return (T-) signal is tied in common to any AI signals on the NI 9237. The NI 9237 connects all the T- signals together internally. Visit [ni.com/info](http://ni.com/info) and enter the info code `rdteds` for more information about TEDS sensors.

## NI 9237 Connection Options

Wiring resistance can create errors in bridge circuits. The NI 9237 provides two mechanisms to correct for these errors: remote sensing and shunt calibration.

### Remote Sensing

Remote sensing continuously and automatically corrects for errors in excitation leads, and generally is most appropriate for half- and full-bridge sensors.

Long wire and small gauge wire have greater resistance, which can result in gain error. The resistance in the wires that connect the excitation voltage to the bridge causes a voltage drop, which is a source of gain error. The NI 9237 includes remote sensing to compensate for this gain error. Connect remote sense wires to the points where the excitation voltage wires connect to the bridge

circuit. Refer to Figure 3 for an illustration of how to connect remote sense wires to the NI 9237.

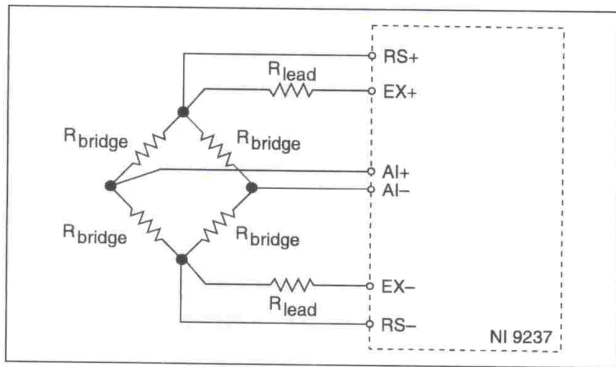

Figure 3. Connecting Remote Sense Wires to the NI 9237

The actual bridge excitation voltage is smaller than the voltage at the EX+ and EX- leads. If you do not use remote sensing of the actual bridge voltage, the resulting gain error is:

$$\frac{R_{lead}}{R_{bridge}} \text{ for half-bridge sensors and}$$

$$\frac{2 \cdot R_{lead}}{R_{bridge}} \text{ for full-bridge sensors.}$$

If you connect the remote sense signals directly to the bridge resistors, the NI 9237 senses the actual bridge voltage and eliminates the gain errors caused by the resistance of the EX+ and EX- leads.

### Shunt Calibration

Shunt calibration can correct for errors from the resistance of both the excitation wiring and wiring in the individual resistors of the bridge. Remote sensing corrects for resistances from the EX pins on the NI 9237 to the sensor, and shunt calibration corrects for these errors and for errors caused by wire resistance within an arm of the bridge. Shunt calibration is most useful with quarter-bridge

sensors because there may be significant resistance in the wiring to the active resistor in the bridge.

The NI 9237 shunt calibration circuitry consists of a precision resistor and a software-controlled switch. Refer to the software help for information about enabling the shunt calibration switch for the NI 9237.

Shunt calibration involves simulating the input of strain by changing the resistance of an arm in the bridge by some known amount. This is accomplished by shunting, or connecting, a large resistor of known value across one arm of the bridge, creating a known strain-induced change in resistance. You can then measure the output of the bridge and compare it to the expected voltage value. You can use the results to correct gain errors in the entire measurement path, or to simply verify general operation to gain confidence in the setup.

Use a stable signal, which is typically the unloaded state of the sensor, first with the shunt calibration switch off and then again with the switch on. The difference in these two measurements provides an indication of the gain errors from wiring resistances. You can design the software application to correct subsequent readings for this gain error.

## Excitation Voltages

Although the sensor industry does not recognize a single standard excitation voltage level, excitation voltage levels of between 2.5 V and 10 V are common. You can program the NI 9237 to supply 2.5 V, 3.3 V, 5 V, or 10 V of excitation voltage, and the module can provide up to 150 mW of excitation power. Unless you supply external excitation voltage, National Instruments recommends that you set the excitation voltage to a value that keeps the total power below 150 mW. The NI 9237 automatically reduces internal excitation voltages as needed to stay below 150 mW total power.

The power consumed by a single bridge is  $\frac{V_{ex}^2}{R}$  where  $R$  is the total resistance of the bridge.

For a quarter or half bridge,  $R$  is equal to two times the resistance of each element. For a full bridge,  $R$  is equal to the resistance of each element.



The 150 mW limit allows you to power half and full bridges as follows:

- Four 350  $\Omega$  half bridges at 5.0 V
- Four 350  $\Omega$  full bridges at 3.3 V
- Four 120  $\Omega$  half bridges at 2.5 V

If you need an excitation voltage that causes more than 150 mW to dissipate across all the bridges, use the EX+ and EX- terminals on the external excitation voltage connector to connect an external excitation source to the NI 9237.

## Understanding NI 9237 Filtering

The NI 9237 uses a combination of analog and digital filtering to provide an accurate representation of in-band signals while rejecting out-of-band signals. The filters discriminate between signals based on the frequency range, or bandwidth, of the signal. The three important bandwidths to consider are the passband, the stopband, and the alias-free bandwidth.

The NI 9237 represents signals within the passband, as quantified primarily by passband flatness and phase nonlinearity. All signals that appear in the alias-free bandwidth are either unaliased signals

or signals that have been filtered by at least the amount of the stopband rejection.

## Passband

The signals within the passband have frequency-dependent gain or attenuation. The small amount of variation in gain with respect to frequency is called the passband flatness. The digital filters of the NI 9237 adjust the frequency range of the passband to match the data rate. Therefore, the amount of gain or attenuation at a given frequency depends on the data rate. Figure 4 shows typical passband flatness for the NI 9237.

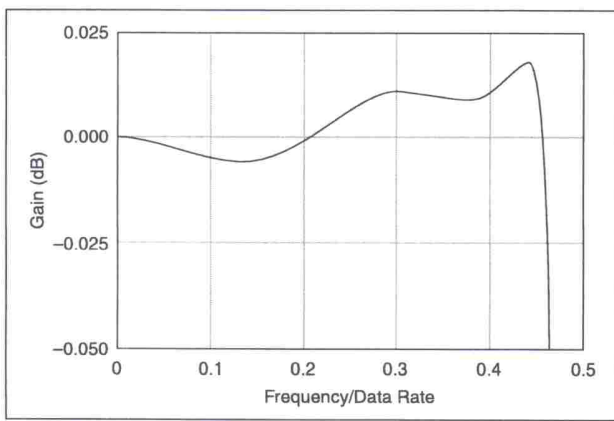

Figure 4. Typical Passband Flatness for the NI 9237

## Stopband

The filter significantly attenuates all signals above the stopband frequency. The primary goal of the filter is to prevent aliasing. Therefore, the stopband frequency scales precisely with the data

rate. The stopband rejection is the minimum amount of attenuation applied by the filter to all signals with frequencies within the stopband.

## Alias-Free Bandwidth

Any signal that appears in the alias-free bandwidth of the NI 9237 is not an aliased artifact of signals at a higher frequency. The alias-free bandwidth is defined by the ability of the filter to reject frequencies above the stopband frequency and equals the data rate minus the stopband frequency.

## Understanding NI 9237 Data Rates

The frequency of a master timebase ( $f_M$ ) controls the data rate ( $f_s$ ) of the NI 9237. The NI 9237 includes an internal master timebase with a frequency of 12.8 MHz, but the module also can accept an external master timebase or export its own master timebase. To synchronize the data rate of an NI 9237 with other modules that use master timebases to control sampling, all of the modules must share a single master timebase source. Refer to the software help for information about configuring the master timebase source for the NI 9237. Visit [ni.com/info](http://ni.com/info) and enter `cseriesdoc` for information about C Series documentation.

The following equation provides the available data rates of the NI 9237:

$$f_s = \frac{f_M \div 256}{n}$$

where  $n$  is any integer from 1 to 31.

However, the data rate must remain within the appropriate data rate range. Refer to the *Specifications* section for more information about the data rate range. When using the internal master timebase of 12.8 MHz, the result is data rates of 50 kS/s, 25 kS/s, 16.67 kS/s, and so on down to 1.613 kS/s, depending on the value of  $n$ . When using an external timebase with a frequency other than 12.8 MHz, the NI 9237 has a different set of data rates.



**Note** The cRIO-9151 R Series Expansion chassis does not support sharing timebases between modules.

## Sleep Mode

This module supports a low-power sleep mode. Support for sleep mode at the system level depends on the chassis that the module is plugged into. Refer to the chassis manual for information about

support for sleep mode. If the chassis supports sleep mode, refer to the software help for information about enabling sleep mode. Visit [ni.com/info](http://ni.com/info) and enter `cseriesdoc` for information about C Series documentation.

Typically, when a system is in sleep mode, you cannot communicate with the modules. In sleep mode, the system consumes minimal power and may dissipate less heat than it does in normal mode. Refer to the *Specifications* section for more information about power consumption and thermal dissipation.

## Specifications

The following specifications are typical for the range  $-40$  to  $70$  °C unless otherwise noted.

### Input Characteristics

Number of channels .....	4 analog input channels
Bridge completion	
Half and Full.....	Internal
Quarter.....	External
ADC resolution .....	24 bits

Type of ADC.....Delta-Sigma (with analog prefiltering)

Sampling mode ..... Simultaneous

Internal master timebase ( $f_M$ )

    Frequency ..... 12.8 MHz

    Accuracy.....  $\pm 100$  ppm max

Data rate range ( $f_s$ ) using internal master timebase

    Minimum ..... 1.613 kS/s

    Maximum ..... 50 kS/s

Data rate range ( $f_s$ ) using external master timebase

    Minimum ..... 390.625 S/s

    Maximum ..... 51.3 kS/s

Data rates<sup>1</sup> ( $f_s$ ) .....  $\frac{f_M \div 256}{n}$ ,  $n = 1, 2, \dots, 31$

Typical input range .....  $\pm 25$  mV/V

Scaling coefficient ..... 2.9802 nV/V per LSB

<sup>1</sup> The data rate must remain within the appropriate data rate range. Refer to the *Understanding NI 9237 Data Rates* section for more information.

Overvoltage protection between any two pins.....  $\pm 30$  V

Accuracy

Measurement Conditions*	Percent of Reading (Gain Error)	Percent of Range** (Offset Error)
Calibrated typ (25 °C, $\pm 5$ °C)	0.05%	0.05%
Calibrated max (-40 to 70 °C)	0.20%	0.25%
Uncalibrated typ (25 °C, $\pm 5$ °C)	0.20%	0.1%
Uncalibrated max (-40 to 70 °C)	0.60%	0.35%

\* Before offset null or shunt calibration.  
\*\* Range equals 25 mV/V.

Gain drift..... 10 ppm/°C max

Offset drift

    2.5 V excitation ..... 0.6  $\mu$ V/V per °C

    3.3 V excitation ..... 0.5  $\mu$ V/V per °C

    5 V excitation ..... 0.3  $\mu$ V/V per °C

    10 V excitation ..... 0.2  $\mu$ V/V per °C

Channel-to-channel matching (calibrated)

Input Signal Frequency ( $f_{in}$ )	Gain		Phase
	Typical	Maximum	Maximum
0 to 1 kHz	0.15%	0.3%	0.125°/kHz · $f_{in}$
1 to 20 kHz	0.4%	1.1%	

Phase nonlinearity

$f_{in} = 0$  to 1 kHz..... <0.001°

$f_{in} = 0$  to 20 kHz..... ±0.1°

Input delay ..... 38.4 $f_s$  + 4.8 μs

Passband

Frequency ..... 0.45 ·  $f_s$

Flatness ..... 0.1 dB max

Stopband

Frequency ..... 0.55 ·  $f_s$

Rejection..... 100 dB

Alias-free bandwidth ..... 0.45 ·  $f_s$

Oversample rate ..... 64 ·  $f_s$

Rejection at oversample rate<sup>1</sup>

$f_s = 10$  kS/s..... 60 dB @ 640 kHz

$f_s = 50$  kS/s..... 90 dB @ 3.2 MHz

Common-mode voltage,

all signals to earth ground..... ±60 VDC

CMRR

Relative to earth ground<sup>2</sup>

( $f_{in} = 0$  to 60 Hz)..... 140 dB

Relative to EX-

( $f_{in} = 0$  to 1 kHz)..... 85 dB

SFDR (1 kHz, -60 dBFS)..... 106 dB

Total Harmonic Distortion (THD)

1 kHz, -20 dBFS ..... 100 dB

8 kHz, -20 dBFS ..... 90 dB

<sup>1</sup> Rejection by analog prefilter of signal frequencies at oversample rate.

<sup>2</sup> Measured with a balanced cable. Shielded cables that are not twisted-pair may be significantly unbalanced. To improve the balance of shielded, twisted-pair cables, NI recommends twisting together the AI+/AI- pair, the RS+/RS- pair, and the EX+/EX- pair.

Input noise

Excitation Voltage	Density (nV/V <sub>rms</sub> per $\sqrt{1\text{ Hz}}$ )	Total, $f_{in} = 0$ to 25 kHz ( $\mu\text{V}/V_{\text{rms}}$ )	Total, $f_{in} = 0$ to 1 kHz (nV/V <sub>rms</sub> )
2.5 V	8	1.3	250
3.3 V	6	1.0	190
5 V	4	0.6	130
10 V	2	0.3	65

Excitation noise ..... 0.1 mV/V<sub>rms</sub>

Crosstalk

$f_{in} = 1$  kHz ..... 110 dB

$f_{in} = 10$  kHz ..... 100 dB

Excitation

Internal voltage ..... 2.5 V, 3.3 V, 5.0 V, 10.0 V

Internal power ..... 150 mW max

External voltage ..... 2 V to 10 V

Shunt calibration

Resistance ..... 100 k $\Omega$

Resistor accuracy

25°C .....  $\pm 110 \Omega$

-40 to 70°C .....  $\pm 200 \Omega$

MTBF ..... 603,359 hours at 25 °C;  
Bellcore Issue 2, Method 1,  
Case 3, Limited Part Stress  
Method



**Note** Contact NI for Bellcore MTBF specifications at other temperatures or for MIL-HDBK-217F specifications.

Power Requirements

Power consumption from chassis

Active mode ..... 740 mW max

Sleep mode ..... 25  $\mu\text{W}$  max

Thermal dissipation (at 70 °C)

Active mode ..... 740 mW max

Sleep mode ..... 25  $\mu\text{W}$  max

## Physical Characteristics

If you need to clean the module, wipe it with a dry towel.

Weight..... 152 g (5.4 oz)

## Safety

### Safety Voltages

Connect only voltages that are within the following limits.

Between any two pins .....  $\pm 30$  V max

#### Isolation

Channel-to-channel ..... None

Channel-to-earth ground

Continuous ..... 60 VDC, Measurement Category I

Withstand ..... 1,000 V<sub>rms</sub>, verified by a 5 s dielectric withstand test

Measurement Category I is for measurements performed on circuits not directly connected to the electrical distribution system referred to as *MAINS* voltage. *MAINS* is a hazardous live electrical supply system that powers equipment. This category is for

measurements of voltages from specially protected secondary circuits. Such voltage measurements include signal levels, special equipment, limited-energy parts of equipment, circuits powered by regulated low-voltage sources, and electronics.



**Caution** Do not connect the NI 9237 to signals or use for measurements within Measurement Categories II, III, or IV.

### Hazardous Locations

U.S. (UL) .....	Class I, Division 2, Groups A, B, C, D, T4; Class I, Zone 2, AEx nC IIC T4
Canada (C-UL) .....	Class I, Division 2, Groups A, B, C, D, T4; Class I, Zone 2, Ex nC IIC T4
Europe (DEMKO).....	EEx nC IIC T4

## Safety Standards

This product meets the requirements of the following standards of safety for electrical equipment for measurement, control, and laboratory use:

- IEC 61010-1, EN 61010-1
- UL 61010-1, CSA 61010-1



**Note** For UL and other safety certifications, refer to the product label or the *Online Product Certification* section.

## Electromagnetic Compatibility

This product meets the requirements of the following EMC standards for electrical equipment for measurement, control, and laboratory use:

- EN 61326 (IEC 61326): Class A emissions; Basic immunity
- EN 55011 (CISPR 11): Group 1, Class A emissions
- AS/NZS CISPR 11: Group 1, Class A emissions
- FCC 47 CFR Part 15B: Class A emissions
- ICES-001: Class A emissions



**Note** For the standards applied to assess the EMC of this product, refer to the *Online Product Certification* section.



**Note** For EMC compliance, operate this device with shielded cabling.

## CE Compliance

This product meets the essential requirements of applicable European Directives as follows:

- 2006/95/EC; Low-Voltage Directive (safety)
- 2004/108/EC; Electromagnetic Compatibility Directive (EMC)

## Online Product Certification

Refer to the product Declaration of Conformity (DoC) for additional regulatory compliance information. To obtain product certifications and the DoC for this product, visit [ni.com/certification](http://ni.com/certification), search by module number or product line, and click the appropriate link in the Certification column.



## Shock and Vibration

To meet these specifications, you must panel mount the system.

### Operating vibration

Random (IEC 60068-2-64)..... 5 g<sub>rms</sub>, 10 to 500 Hz

Sinusoidal (IEC 60068-2-6) ..... 5 g, 10 to 500 Hz

### Operating shock

(IEC 60068-2-27)..... 30 g, 11 ms half sine,  
50 g, 3 ms half sine,  
18 shocks at 6 orientations

## Environmental

National Instruments C Series modules are intended for indoor use only but may be used outdoors if installed in a suitable enclosure. Refer to the manual for the chassis you are using for more information about meeting these specifications.

### Operating temperature

(IEC 60068-2-1, IEC 60068-2-2) ..... -40 to 70 °C

### Storage temperature

(IEC 60068-2-1, IEC 60068-2-2) ..... -40 to 85 °C

Ingress protection..... IP 40

### Operating humidity

(IEC 60068-2-56)..... 10 to 90% RH,  
noncondensing

### Storage humidity

(IEC 60068-2-56)..... 5 to 95% RH,  
noncondensing

Maximum altitude..... 2,000 m

Pollution Degree (IEC 60664) ..... 2

## Environmental Management

NI is committed to designing and manufacturing products in an environmentally responsible manner. NI recognizes that eliminating certain hazardous substances from our products is beneficial to the environment and to NI customers.

For additional environmental information, refer to the *NI and the Environment* Web page at [ni.com/environment](http://ni.com/environment). This page contains the environmental regulations and directives with which NI complies, as well as other environmental information not included in this document.

## Waste Electrical and Electronic Equipment (WEEE)



**EU Customers** At the end of the life cycle, all products *must* be sent to a WEEE recycling center. For more information about WEEE recycling centers and National Instruments WEEE initiatives, visit [ni.com/environment/weee](http://ni.com/environment/weee).

## 电子信息产品污染控制管理办法 (中国 RoHS)



**中国客户** National Instruments 符合中国电子信息产品中限制使用某些有害物质指令 (RoHS)。关于 National Instruments 中国 RoHS 合规性信息, 请登录 [ni.com/environment/rohs\\_china](http://ni.com/environment/rohs_china)。(For information about China RoHS compliance, go to [ni.com/environment/rohs\\_china](http://ni.com/environment/rohs_china).)

## Calibration

You can obtain the calibration certificate and information about calibration services for the NI 9237 at [ni.com/calibration](http://ni.com/calibration).

Calibration interval ..... 1 year

## Where to Go for Support

The National Instruments Web site is your complete resource for technical support. At [ni.com/support](http://ni.com/support) you have access to everything from troubleshooting and application development self-help resources to email and phone assistance from NI Application Engineers.

National Instruments corporate headquarters is located at 11500 North Mopac Expressway, Austin, Texas, 78759-3504. National Instruments also has offices located around the world to help address your support needs. For telephone support in the United States, create your service request at [ni.com/support](http://ni.com/support) and follow the calling instructions or dial 512 795 8248. For telephone support outside the United States, contact your local branch office:

Australia 1800 300 800, Austria 43 662 457990-0,  
Belgium 32 (0) 2 757 0020, Brazil 55 11 3262 3599,  
Canada 800 433 3488, China 86 21 5050 9800,  
Czech Republic 420 224 235 774, Denmark 45 45 76 26 00,  
Finland 358 (0) 9 725 72511, France 01 57 66 24 24,  
Germany 49 89 7413130, India 91 80 41190000,  
Israel 972 3 6393737, Italy 39 02 41309277, Japan 0120-527196,

Korea 82 02 3451 3400, Lebanon 961 (0) 1 33 28 28,  
Malaysia 1800 887710, Mexico 01 800 010 0793,  
Netherlands 31 (0) 348 433 466, New Zealand 0800 553 322,  
Norway 47 (0) 66 90 76 60, Poland 48 22 3390150,  
Portugal 351 210 311 210, Russia 7 495 783 6851,  
Singapore 1800 226 5886, Slovenia 386 3 425 42 00,  
South Africa 27 0 11 805 8197, Spain 34 91 640 0085,  
Sweden 46 (0) 8 587 895 00, Switzerland 41 56 2005151,  
Taiwan 886 02 2377 2222, Thailand 662 278 6777,  
Turkey 90 212 279 3031, United Kingdom 44 (0) 1635 523545

National Instruments, NI, ni.com, and LabVIEW are trademarks of National Instruments Corporation. Refer to the *Terms of Use* section on [ni.com/legal](http://ni.com/legal) for more information about National Instruments trademarks. Other product and company names mentioned herein are trademarks or trade names of their respective companies. For patents covering National Instruments products/technology, refer to the appropriate location: **Help»Patents** in your software, the `patents.txt` file on your media, or the *National Instruments Patent Notice* at [ni.com/patents](http://ni.com/patents).

© 2006–2008 National Instruments Corp. All rights reserved.  
Printed in Hungary.

324186C-01

Aug08

